

# KP716 HOIST MOUNTING INSTRUCTIONS

STUDY NAMES AND LOCATIONS OF THE PARTS AND FAMILIARIZE YOURSELF WITH THE HOOK HOIST BEFORE STARTING THE INSTALLATION. READING THE STEP-BY-STEP INSTRUCTIONS THAT FOLLOW WILL BE HELPFUL.

## SAFETY



Read all of the Safety Notations in the following instructions for your own protection. Accidents can be prevented by recognizing the cause of an accident before it can happen.

## INSTALLATION

Select an area for installation that will be large enough to accommodate the completed unit. The surface of the work area should be as level as possible. Use the proper hand tools to insure proper bolt tightness. Refer to the bolt chart on the previous page for the recommended torque values for different sizes of bolts.

If a forklift is to be used to lift the KP716 from the transport vehicle to the installation area, care should be taken not to engage chains or hooks to areas of the Hook Hoist which may cause damage to hydraulic hoses or any parts of the structure.

Before starting installation procedures, check the shipping list to ensure that all parts and accessories have been supplied. Any missing items should be reported to K-PAC immediately.



## MODEL NUMBER

Know the model number of the KP716 being mounted.

Use this model number whenever referring to assembly or parts

listing pages. The number is stamped on a Name Plate which is located on the frame member.

## CHASSIS SPECIFICATIONS

SINGLE AXLE TRUCK

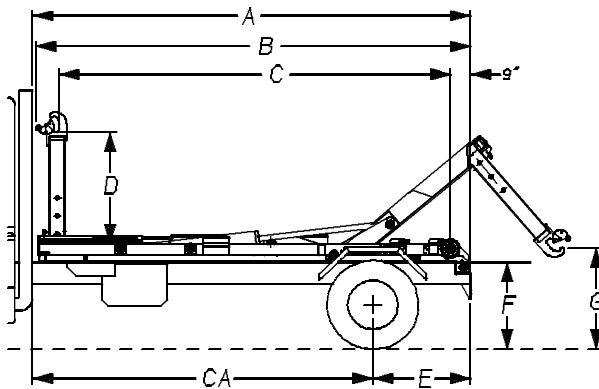

TANDEM AXLE TRUCK

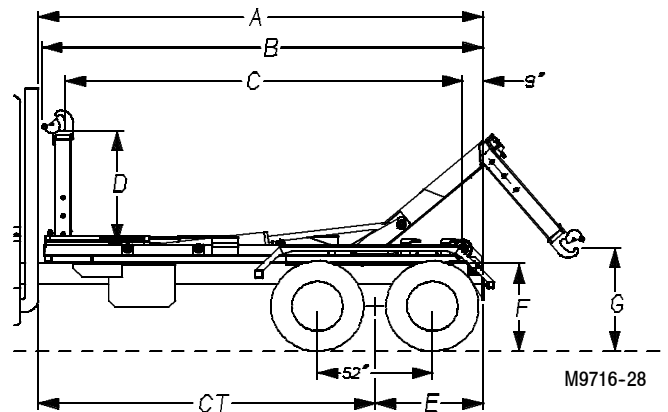

MODEL	A	B	C	D	E		F	G	
					SINGLE	TANDEM		54" boom	62" boom
KP716-138	183"	181.5"	161.50"	52.75"	45"	49"	41"	48"	42"
KP716-156	201"	199.5"	179.50"	60.50"	28"	49"	41"	48"	42"

The **KP716-138 / KP716-156 Hook Hoist** is designed for a 30,000-46,000 lb. G.V.W.R. chassis with 138"/156" unobstructed behind cab-to-axle or trunnion chassis clearance. Some truck suspensions will allow frame cut-off less than 38". It is desirable to have the axle back as far as possible, so a longer cab-to-axle chassis can be used. If the suspension allows shorter than 21" then check fender clearance. This is based on a K-PAC single axle fender. Note: This information is supplied for guidelines only and does not assure the installer of other mounting considerations.

**Dimension "A"** is the minimum cab to frame cut-off dimension and should be increased if a taper or toolbox, etc. is to be added. Also, be aware of exhausts, etc. behind the cab, measuring from the rearmost obstruction.

## Truck Chassis cab-to-axle or cab-to-trunnion Specification formula:

Determine shortest "E" dimension possible with desired suspension. Also determine extra behind cab clearance for tarper, toolbox, or other accessories. Then use the following formula to determine CA or CT to specify: **Single Axle (CA) = A - E + extra clearance**

**Tandem Axle (CT) = A - E + extra clearance**

The preceding illustrations provide dimensional guidelines for compatibility with containers, etc. If the chassis is higher or lower than the 41" dimension shown, then the lowest hook pickup dimension will change accordingly.

## HOOK HOIST MOUNTING INSTRUCTIONS

NOTE: RIGHT and LEFT sides can be established by standing behind the truck frame and looking towards the front or the direction of travel.

The KP716 Hook Hoist is designed to mount on a standard truck frame. If there are unmovable obstructions on top of the truck frame, you must add spacers to raise the hoist frame to clear, or move the obstructions.

1. Compare the Truck Chassis with the Hook Hoist ordered (138CA / 156CA Hoist). Compare the specification dimensions to determine how far forward on the chassis the Hoist can be mounted. It is best to mount as far forward as possible for optimum weight distribution. Suspension and fender to rear holdown are the main considerations. See truck chassis Cab-To-Axle or CA-to-Trunnion specifications formulas above.
2. If chassis is longer than the above CA's the chassis can be cut off shorter per difference. Cut end of frame per illustration shown at right.

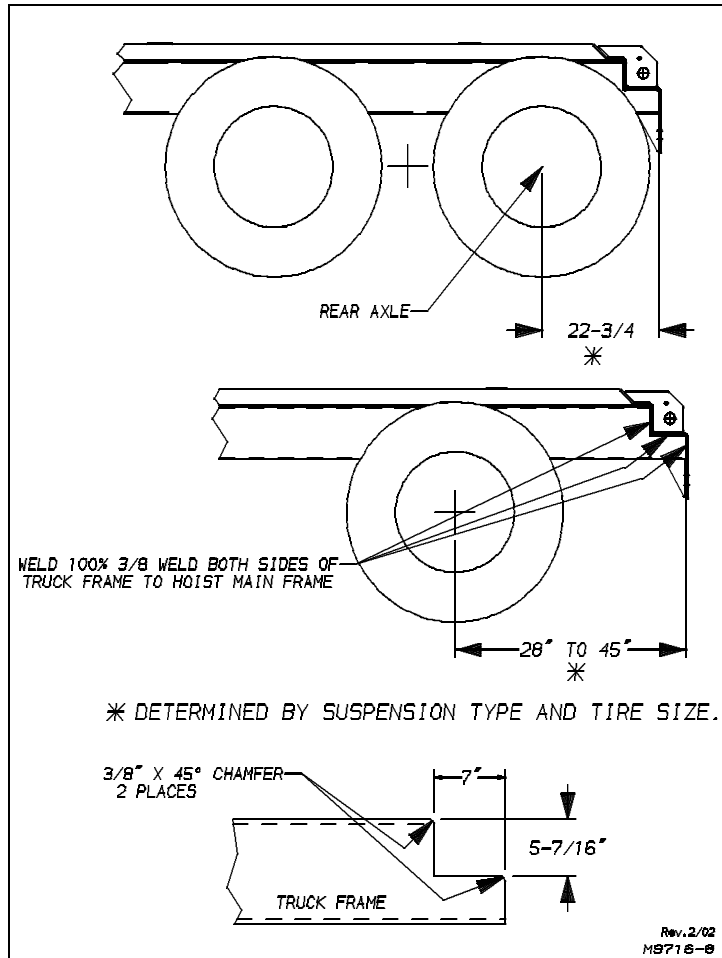

Measure and mark truck frame per axle location and type (i.e. single, tandem). Measure assembled hoist to be sure adequate room is available behind truck cab, between bumper and tires and between fender and tires. After double-checking your measurements, step-cut the frame to dimension. Grind the top of each cut to a 3/8" x 45 chamfer to clear radius on top of hoist main frame rear apron. Install hoist mainframe and weld to truck frame as shown. **The minimum would be 1" behind the rear spring shackle.**

NOTE: If bolts, pipe, pipe fittings, hydraulic fittings, hoses, etc., are substituted for the hardware supplied with the hoist, the installer must use parts of equal quality and service strength.

NOTE: It may be necessary to relocate air tanks, fuel tank, battery cases or any other accessories mounted in this area.



**Caution:** Before cutting or drilling through the truck chassis, be sure that all hoses, wiring and lines are moved out of the path of the drill.

3. Unpackage the KP716 Hook Hoist Main Frame and prepare to lift it onto the truck chassis.
4. With the Truck Chassis prepared as previously illustrated, safely attach chains and lift the hoist with a heavy duty fork lift or some other suitable lifting device. Move and position the sub-frame over the truck chassis.

5. Lower the sub-frame onto the chassis so that the back plate on the sub-frame aligns with the end of the truck frame. See illustration.
6. Attach (2) 9210-15-22 Front and (6) 9716-0-8 Rear Mounting Brackets as shown in illustration on page A4.
7. Using a 5/8" drill bit, drill holes into the chassis rails matching the Mounting Brackets on the sub-frame.
8. Insert the 5/8" bolts through the brackets and truck frame, install nuts. Tighten all nuts and bolts per bolt torque chart at beginning of this section, matching the bolt grade.

## POWER TAKE-OFF INSTALLATION

**⚠ Caution:** The power take-off selection should be done with care. For diesel engines, the P.T.O. should be 85% to 100% of engine R.P.M. For gas engines, the P.T.O. should be 65% to 80% of engine R.P.M. The direct mounted pump requires a SAE B 2-bolt mounting flange and must accept a 7/8" 13 tooth splined shaft.

**⚠ Warning:** Do not attempt to install or service any power take-off with your truck engine running. Put the ignition keys in your pocket before getting under the truck.

Do not allow truck engine to be started while workmen are under the truck. Block truck wheels with suitable chocks before working under the truck.

**⚠ Warning:** Be sure to block any raised body or mechanism before working on or under the equipment.

Installed power take-offs must never be shifted in or out of gear by any means except by the controls in the cab of the truck.

Stay clear of spinning driveshafts to avoid becoming entangled and injured.

For P.T.O. installation, follow the P.T.O. manufacturer's installation instructions.

When installation is completed, refill the transmission with fluid and run engine for 5 to 10 minutes to check for leaks.

## DIRECT MOUNTED PUMP INSTALLATION

1. To install a direct mounted pump, first of all determine the direction of rotation of the PTO from the illustration below.
2. Align the splined shaft on the pump with the splines in the PTO.
3. Install (2) 1/2NC x 2" GD.5 Cap Screws and Lock Washers. Be sure the pump flange is fully seated onto the PTO housing.

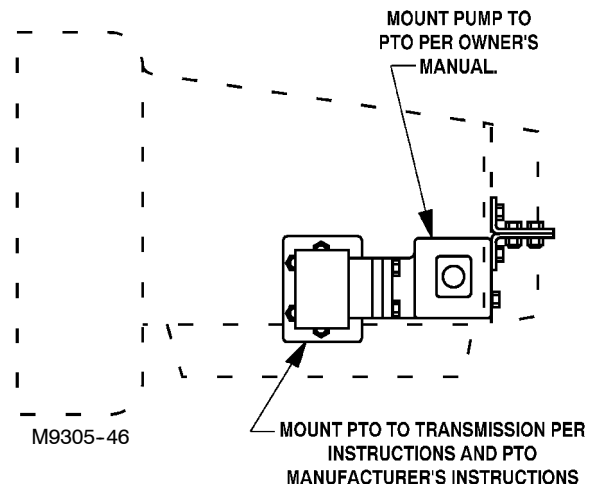
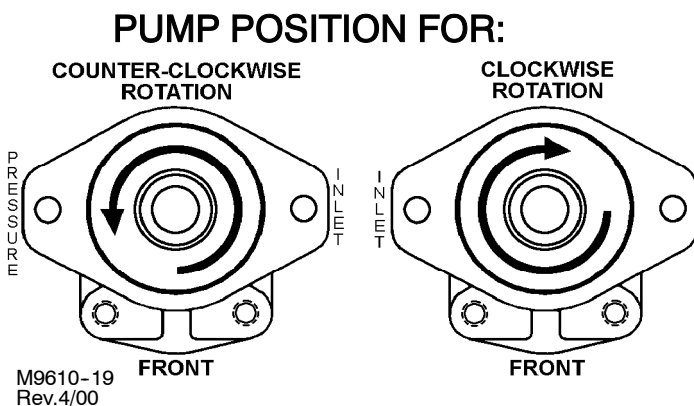

4. Tighten all hardware.

**⚠ Warning:** Direct mounted hydraulic pumps weighing more than 50 Lbs. should be supported at the rear by a strap attached to the transmission.

# OIL TANK, VALVE AND HOSE INSTALLATION

Clean all hydraulic components and keep all hoses, tubes, valves and fittings capped until they are to be installed.

**BE SURE TO READ THE SAFETY INFORMATION THAT FOLLOWS!**

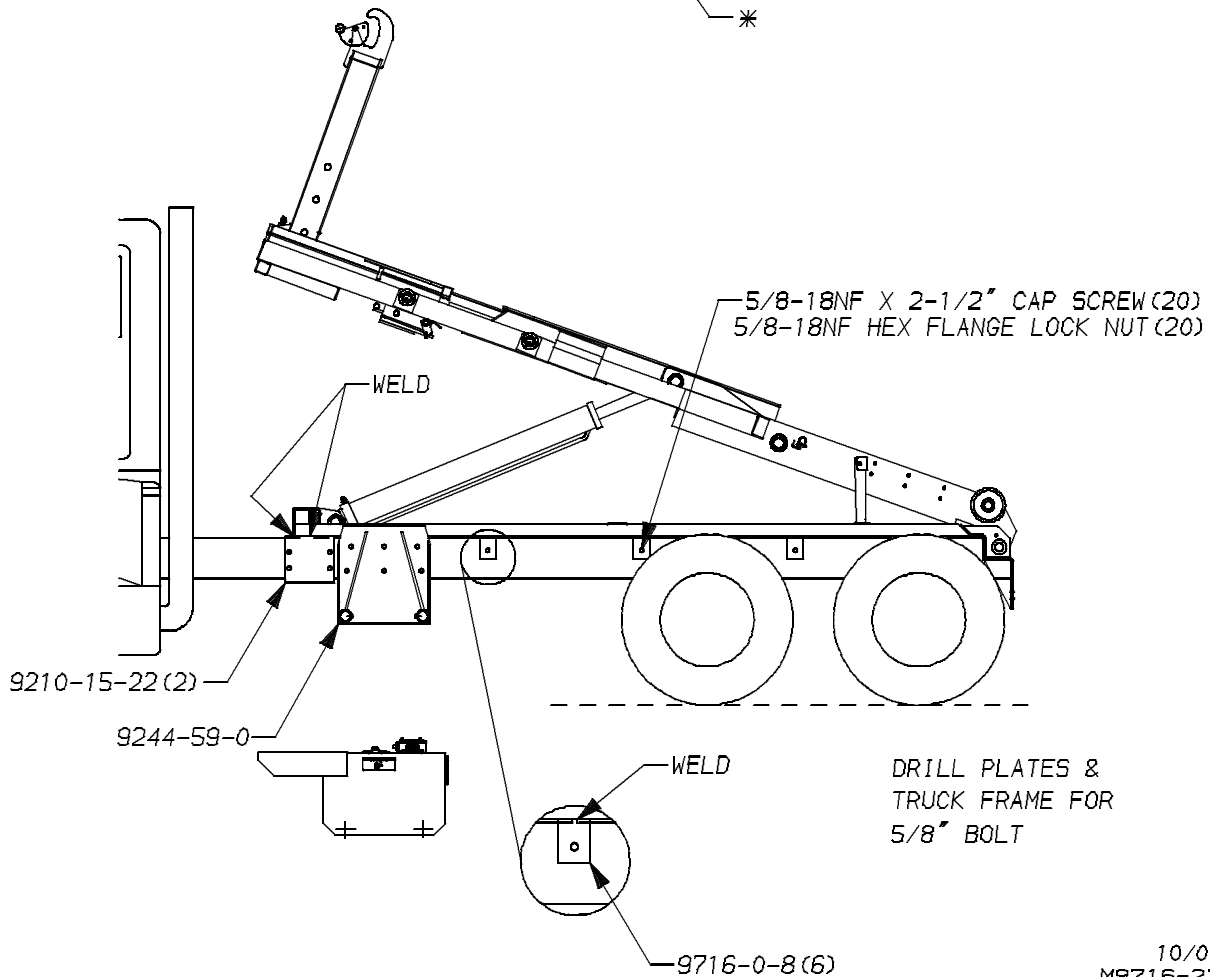
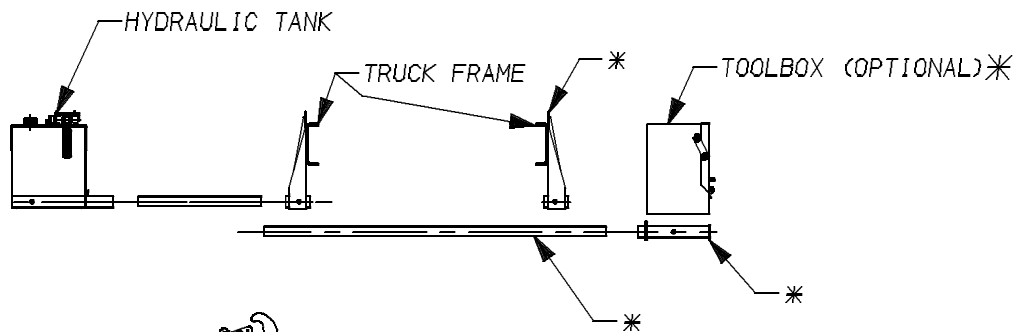
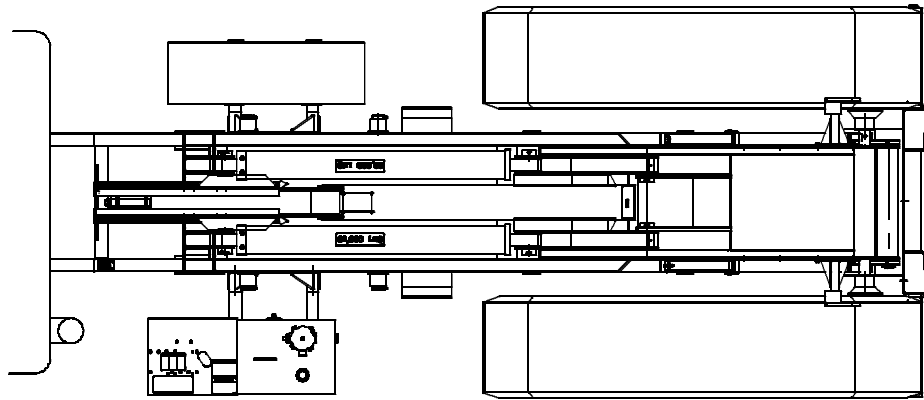

10/01  
MS716-27

# HYDRAULIC TANK INSTALLATION - REFER TO PARTS SECTION PAGE P17

1. Assemble valve, hoses, etc. to tank before mounting tank. Label hoses per illustration.
2. Position and clamp the Tank Mounting Bracket behind the rear of the cab boundary per illustration.

**NOTE:** It may be necessary to relocate air tanks, fuel tanks, battery cases or any other accessories mounted in this area. Check bolt sides for clearance on hydraulic tank and toolbox mounting.



**Warning:** Escaping fluid under pressure can penetrate the skin causing serious injury. Avoid the hazard by relieving pressure before disconnecting hydraulic lines. Tighten all connections before applying pressure.

Search for leaks with a piece of cardboard. Protect hands and body from high pressure fluids.

If an accident occurs, see a doctor immediately. Any fluid injected into the skin must be surgically removed within a few hours or gangrene may result.

3. Drill six (6) 5/8" diameter holes as shown in illustration. Use six (6) 5/8NF x 2-1/2"GD5 Cap Screws.
4. If remote pump is installed, see Remote Mount Pump Installation (pg. A5) before proceeding.
5. Install the Close Nipple, Gate Valve, and Hose Barb onto the Tank Assembly.
6. Remove the Tank Assembly and drill 3/8" diameter holes on the marks.
7. Re-install the tank and tighten the set screws into the drilled holes. Tighten the jam nuts.

## Hydraulic hose routing

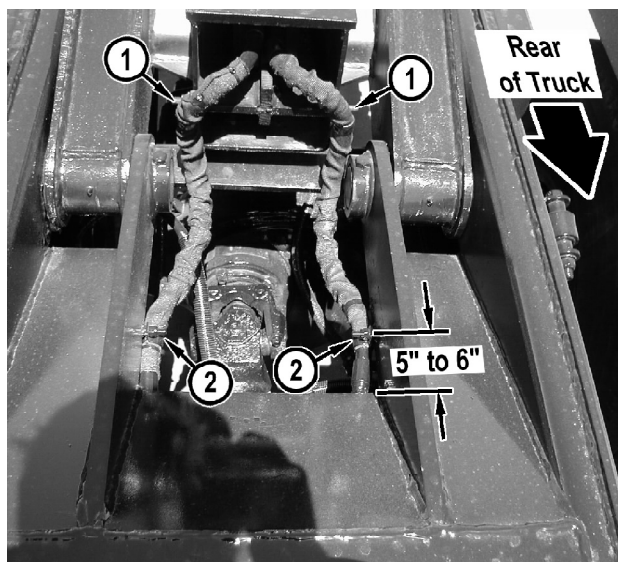

M9716-38

1. Weld a 3/8NC x 1" Bolt level with cylinder mounting plate on both sides as shown (Item 1) in photo to the left.
2. Weld a 3/8NC x 1" Bolt approximately 5" to 6" in front of angled plate on the inside just above bottom of side plate, both sides (Item 2) as shown in photo to the left.

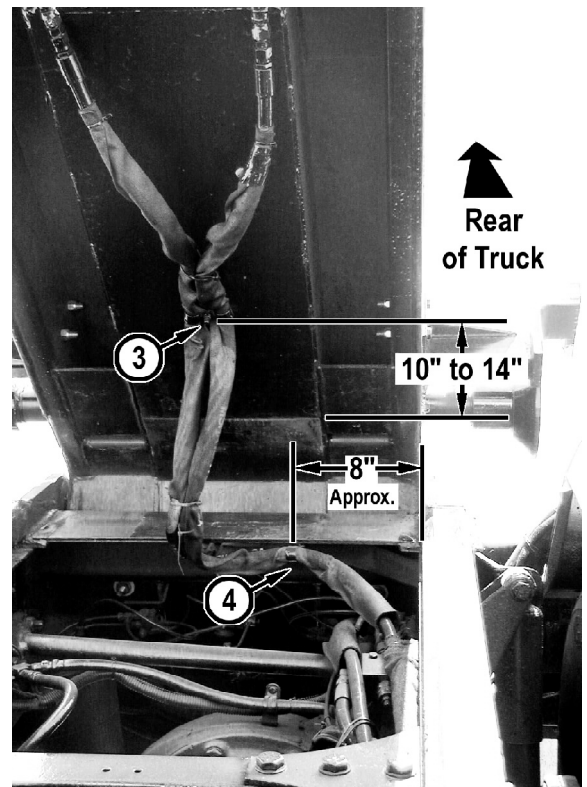

M9716-39

3. Weld a 3/8NC x 1-1/2" bolt in center of plate as shown (Item 3) in photo to the right.
4. Weld a 3/8NC x 1-1/2" bolt to bottom inside of rear apron on main frame approximately 8" in from frame edge as shown (Item 4) in photo at right.

Attach hoses using ONE hose clamp at locations 1 and 2 (photo above); TWO hose clamps at locations 3 and 4 (photo at right). Secure clamps with 3/8 lock nuts.

Adjust hoses to allow enough travel and return without getting caught in hoist. Operate through full tilt and full separate boom travel.

## INSIDE CONTROL HANDLE INSTALLATION

Route the control cables under the seat and through the back of the truck cab. Seal the cable holes with grommets.

The right lever cable should be connected to the right side control valve and the left lever cable to the left control valve.

1. Choose a mounting location which is convenient and comfortable for the operator and provides adequate clearance for control lever movement.

NOTE: Check the underside of the cab for reinforcement members, air lines, wiring harnesses, and linkages before cutting into the floor.

**IMPORTANT:** A GOOD CABLE PATH IS ESSENTIAL FOR A PROPERLY OPERATING SYSTEM. BE SURE THAT THE LOCATION CHOSEN ALLOWS THE CABLE TO BE LED EASILY AWAY FROM THE CONTROL, WITH NO BENDS OF LESS THAN 8" RADIUS. THE CONTROLS MAY BE MOUNTED "FLUSH" IN A CONTROL CONSOLE SIDE MOUNTED, OR BANK MOUNTED AND THROUGH BOLTED AS SHOWN IN ILLUSTRATION ON PAGE P22.

2. Cut out a hole for the control cables and drill four (4) 7/16"DIA. mounting holes.
3. Mount the control handle and brackets as shown in parts drawing on page P22. Be sure that control handle movement corresponds with the direction decal as shown on page O2.

## VALVE CONTROL INSTALLATION

1. Control Handles -- remove the bolts holding the spool cover plate, position the handle assembly on the valve face and install the longer bolts. Install the clevis pin and cotter pin.

The cable controls supplied with the K-PAC Hoists are a high quality assembly which seal out moisture, are corrosion protected, and engineered to minimize backlash (lost motion).

After the hoist and hydraulic tank are mounted to the truck chassis, the remote cable controls may be installed.

### Inside Control Handle Installation - Refer to parts page P22

Choose a mounting location which is convenient and comfortable for the operator and provides adequate clearance for control lever movement. Be sure the location chosen allows the cable to be led easily away from the control, with no bends of less than 8" radius. The controls may be mounted flush in a control console, side mounted, or bank mounted together and through bolted as shown above.

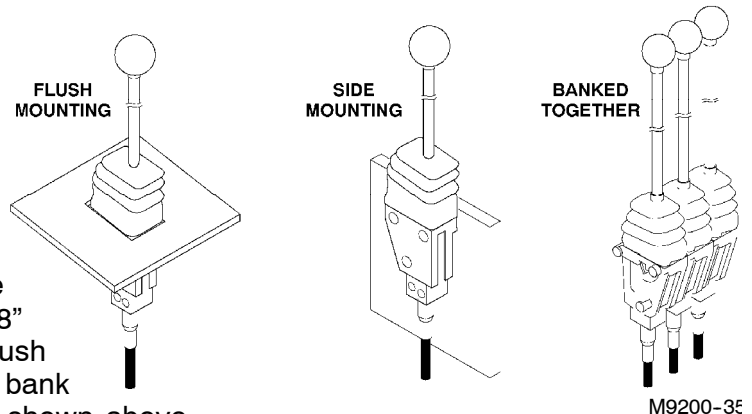

Control operation can be changed simply by turning the control valve through 180°.

**IMPORTANT:** A good cable path is essential for a properly operating system. Keep bends in the cable path to a minimum and as generous as possible. Under no circumstances should any bend be tighter than an 8" radius.

Protect the cable from heat above 225 Fahrenheit, and avoid hot areas such as exhaust pipes etc.

Protect the cable from physical damage, such as pinching or crushing, and do not use cable supports which may crush or deform the cable.

Allow room for flexing where cable is attached to moving parts of the equipment, so that the cable is neither kinked or stretched.

## Cable Connections

1. Install the control head end of the cable, by first removing the cable retaining bolt.
2. Slip the cable housing into the control head and replace the retaining bolt.
3. Check the control for free movement and correct valve control.
4. To connect the cable to the valve handle, start by removing the mounting nut from the cable assembly.
5. Install the threaded portion of the cable assembly through the bulkhead weldment and replace the mounting nut.
6. Install the clevis provided to the cable end and the valve handle.  
NOTE: The cable end should be parallel to the bulkhead weldment.
7. Tighten the cable mounting nut.
8. Screw the control head onto the cable.

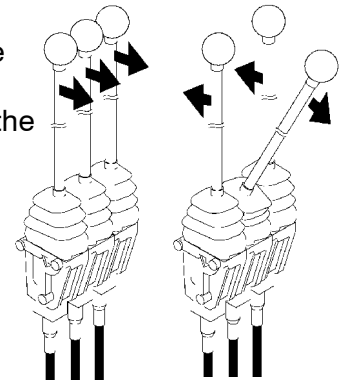

M9200-36

## PNEUMATIC CONTROL INSTALLATION INSTRUCTIONS

The pneumatic controller provided with the K-PAC Hook Hoist are dual three-way regulating valves. Output of the controllers is proportional to the control lever position and is balanced against the force of an internal spring

### Pneumatic Actuator Installation - Refer to parts section page P21

To install the pneumatic actuators to the hydraulic valve, it is best to do so before assembling the valve to hydraulic tank. If this is not possible then remove the valve from the hydraulic tank.

Find a suitable area free of dust and dirt to attach the pneumatic actuators.

1. Set the hydraulic valve on the mounting base.
2. Determine which spools are to be pneumatically controlled.
3. Remove the positioner bonnet (Item 2 above) located on the back end of each spool (opposite from the handle end).
4. Using a 5/16" hex Allen wrench and a screw driver on the handle end of the spool, remove the socket head cap screw (Item 14 at right) retaining the stop collar and spring.

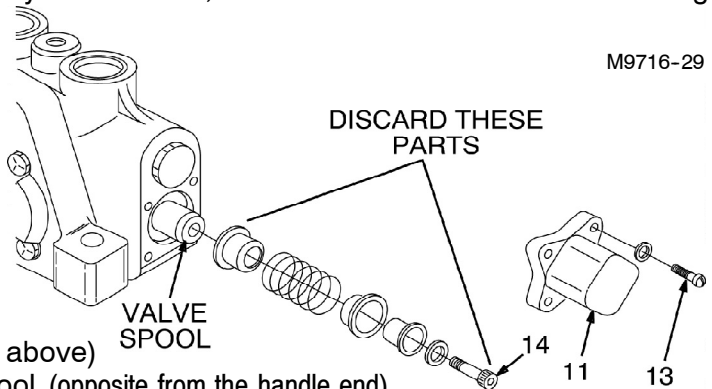

M9716-29

**NOTE:** It may be necessary to give the Allen wrench a sharp rap to break the socket head screw loose.

Discard the spring, socket head screw and TWO spring collars.

### Actuator Installation - (See parts page P21)

The actuator is pre-assembled and need not be disassembled.

For proper operation, the following procedure must be adhered to:

1. Remove bonnet from actuator assembly (Item 2). Note: Hold assembly bolt, washer, spring, etc. together.
2. Install washer (Item 3) onto bolt (Item 1) and mount spacer (Item 4) between actuator assembly and valve. Screw bolt into valve spool and tighten.
3. Install bolts and washer (Item 5 & 6) into valve to retain actuator and tighten.
4. Install bonnet (Item 2) and bolts (Item 13) onto actuator and tighten.
5. Check actuator by applying air pressure to each port and making sure valve spool shifts.

### **Pneumatic Controller Installation (In Dash)**

If the controllers are to be mounted in the cab dash, an area 3.25" high and 1.38" wide for the single unit must be clear of any obstruction to a depth of 3.50" behind the panel. The joystick requires an area 3.38" high, 3.38" wide and 3.5" deep.

## Pneumatic Controller Installation (Tower) - See parts page P21

1. Determine a suitable location which is in a comfortable location for the driver and not in the way of the transmission lever.
2. Position the lower bolt holes so that the bolts will miss any cable, wires or structural members in or under the cab floor.
3. Mark and drill the four (4) .343"DIA. holes for the self-tapping mounting bolts supplied with the tower.
4. Determine a location in the area between the mounting holes to run the air lines.
5. Drill a 2" to 3" DIA. hole through the floor of the truck. Remove all burrs and sharp edges. Line the hole with a suitable grommet material.
6. Using the washers on the under side of the floor, attach the tower to the floor with 3/8" cap screws and lock nuts.
7. Mount the controller(s) to the tower top plate as shown.

After the controllers have been mounted, the plumbing of the air lines can be started.

1. Determine a suitable route for air lines.
2. Cut the necessary holes, remove all burrs, and add grommets to any sharp edges.
3. Determine the line length required, and cut two lines for each actuator.
4. Route the lines between the controllers and the actuators.
5. Bundle the lines together and secure them out of harm's way.

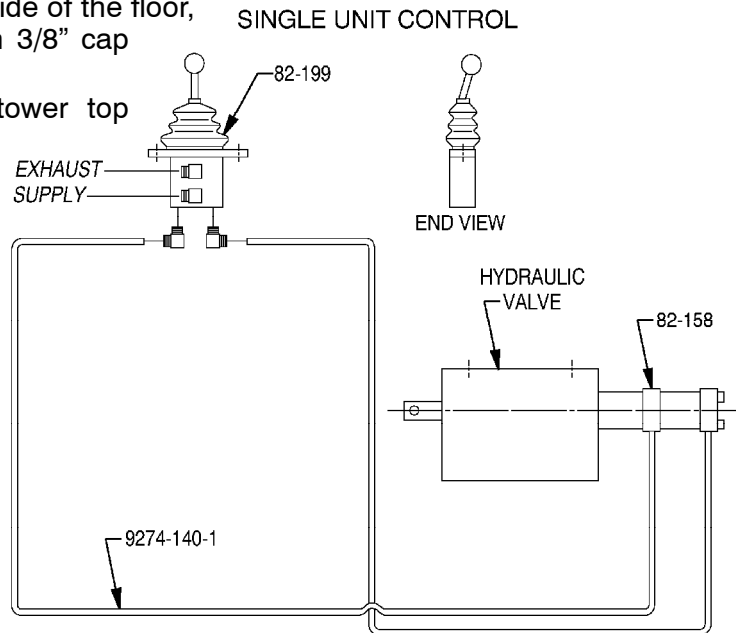

## Joystick Controller & Single Valve Controller

1. Simply square cut the end of the air line and connect each controller port to corresponding actuator port.
2. Attach the supply and exhaust lines as shown.

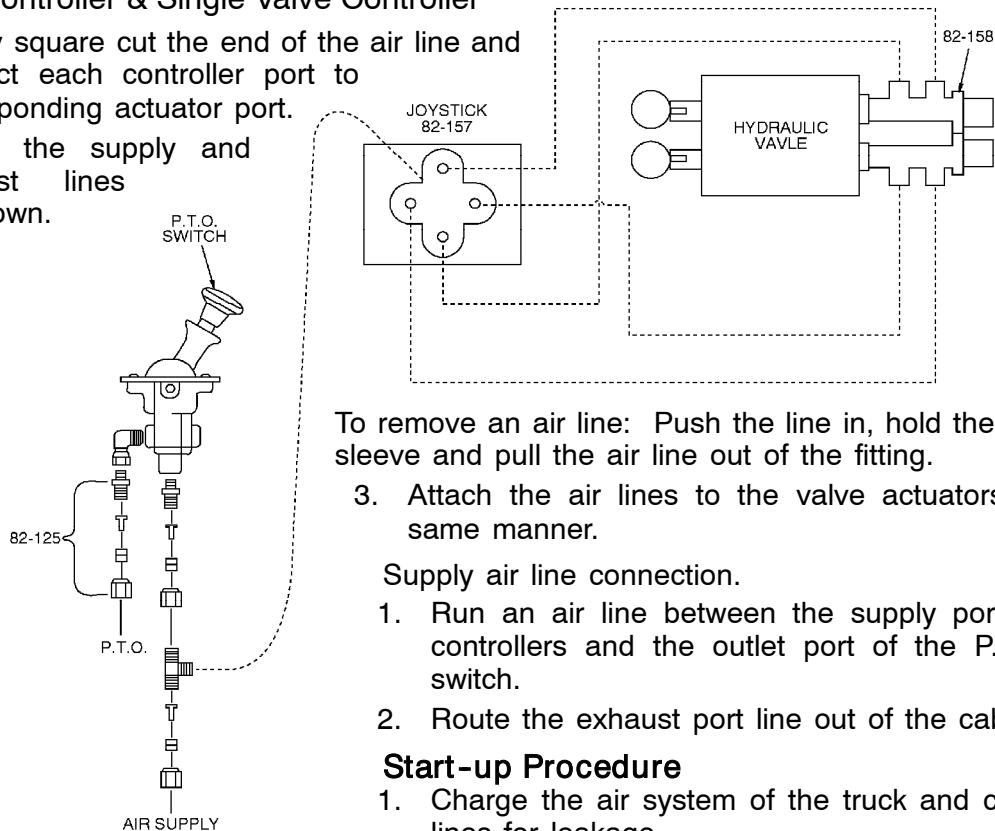

To remove an air line: Push the line in, hold the internal sleeve and pull the air line out of the fitting.

3. Attach the air lines to the valve actuators in the same manner.

### Supply air line connection.

1. Run an air line between the supply port of the controllers and the outlet port of the P.T.O. air switch.
2. Route the exhaust port line out of the cab.

### Start-up Procedure

1. Charge the air system of the truck and check all lines for leakage.

- Operate the controllers and check for correct hydraulic valve movement.

**NOTE:** The controllers pressurize the port toward which the handle is moved. If the function is to be reversed, exchange the air lines at the controller or actuator.

- After the correct connections have been made, and the hoist has been completely installed, engage the P.T.O. to check out the operation of the hoist.

## INNER BOOM HYDRAULIC INTERLOCK INSTALLATION

- Position the switch mounting plate (9716-0-30) on main frame as shown.
- Weld switch mounting plate with 1/4" welds.
- Mount the remote switch (79-248) to mounting plate with 1/8NC x 1-1/4" Cap Screw and Hex Flange Lock Nuts.

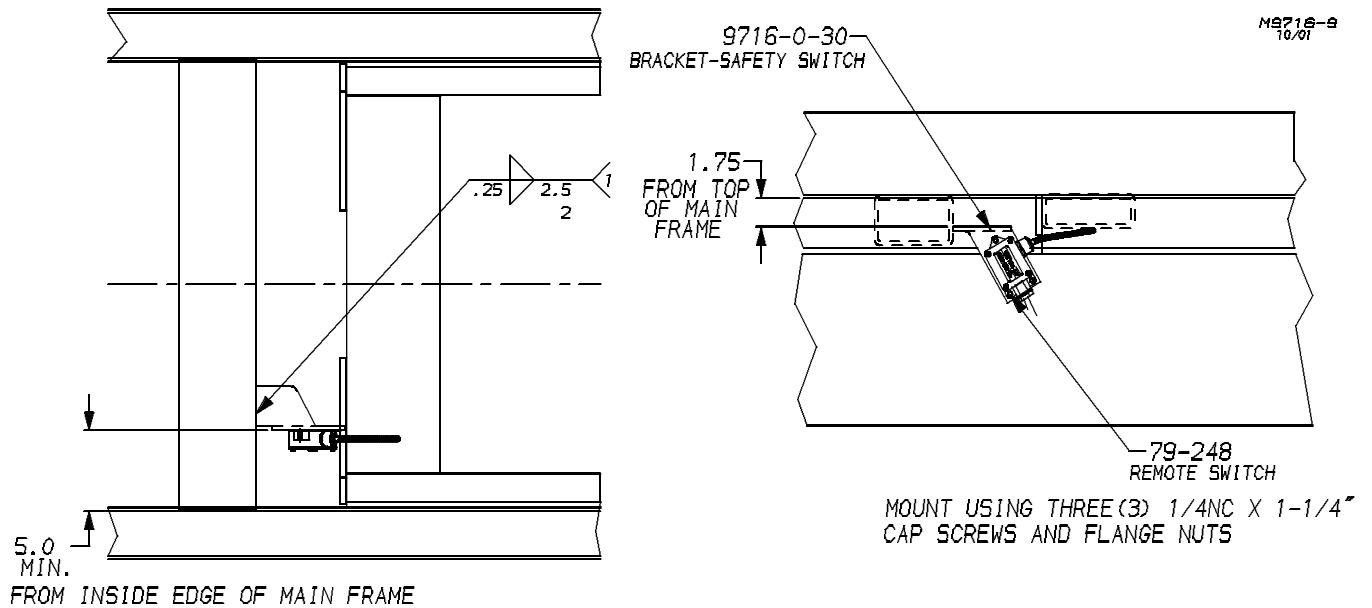

- Wire remote switch to solenoid valve as shown, cap blue wire on relay harness (not used).

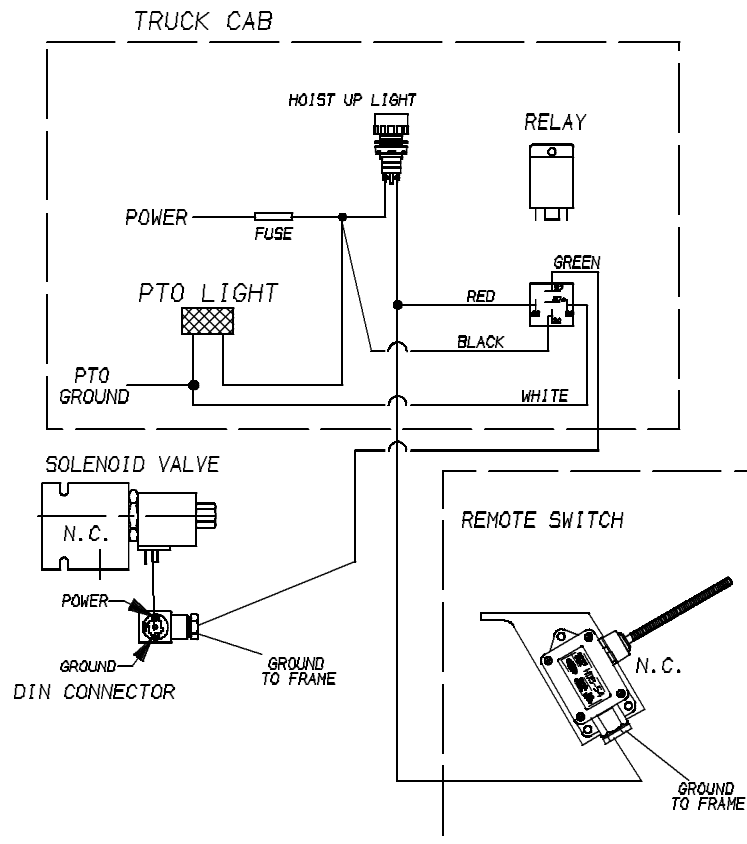

REV.10/02  
M9716-41

## **BUMPER INSTALLATION**

### **Lighted Bumper Installation - Reference Parts pages P5, P8**

1. Remove the cover plate over the right side access hole.
2. Align the lighted bumper with the holes in the apron. Install (1) 5/8NC x 1-1/2" GD.5 Cap Screws, Lock Washers and Hex Nuts. Torque to specifications. Weld solid to Sub-Frame top and bottom. Add bracing angled up to truck frame. Do not weld brace to truck frame, add bolt plate or weld to hoist frame.
3. Install the wiring harness through the left side access hole.
4. Slip a grommet onto the harness leads and pull through the 5/8" DIA. hole.
5. Attach the ground wire to the bumper with a 3/8" self tapping screw.
6. Install the bumper lights as shown on parts page P5.
7. Connect the leads from the wiring harness to the truck wiring as shown on parts page P9.  
**For 4-Wire systems:** If truck has 5-Wire system, do not tie the Stop Light and Turn Light together. Instead, tie both the Left Hand and Right Hand Stop Light wires together.
8. Back-Up Alarm.
  1. To install the back-up alarm, run the white and blue leads with bullet sockets through the left side cover plate. Install the cover plate with four (4) 3/8" self-tapping screws. (See drawing on parts section page P5)
  - A. Attach the back-up alarm to the cover plate with two (2) 3/8" self-tapping screws.
  - B. Connect the white wire to the (-) terminal on the alarm, and the blue wire to the (+) terminal.
  - C. Install the "Alarm Must Sound" decal in the cab in FULL VIEW of the operator.  
**IMPORTANT:** THE BACK-UP ALARM SHOULD SOUND WHEN THE BACK-UP LIGHTS ARE ON.

## **WIRING HARNESS INSTALLATION**

The KP716 should be wired in the manner recommended by the truck manufacturer and should adhere to the laws governing vehicles of the same classification.

Install the side marker light assembly and connect the electrical wiring harness for the brake lights, rear marker lights and reverse lights.

Install the bumper plate cover on both sides.

Install rear identification light assembly.

## **REAR STABILIZER INSTALLATION**

1. Align the stabilizer with top hole in apron. Install (1) 5/8NC x 1-1/2" GD5 Cap Screw, Lock Washer, and Hex Nut. Level stabilizer and torque to specifications.
2. Weld solid all around, apron to stabilizer.
3. Brace lower part of stabilizer to truck frame with some type of angle brace, 1/2" x 2" Strap or stronger.
4. Install the wiring harness through the left side access hole.
5. Slip a grommet onto the harness leads and pull through the 5/8" DIA. hole.
6. Attach the ground wire to the bumper with a 3/8" self tapping screw.
7. Install the bumper lights as shown on parts page P5.
8. Connect the leads from the wiring harness to the truck wiring as shown on parts page P9.  
**For 4-Wire systems:** If truck has 5-Wire system, do not tie the Stop Light and Turn Light together. Instead, tie both the Left Hand and Right Hand Stop Light wires together.
9. Back-Up Alarm.
  1. To install the back-up alarm, run the white and blue leads with bullet sockets through the left side cover plate. Install the cover plate with four (4) 3/8" self-tapping screws. (See drawing on parts section page P5)
  - A. Attach the back-up alarm to the cover plate with two (2) 3/8" self-tapping screws.
  - B. Connect the white wire to the (-) terminal on the alarm, and the blue wire to the (+) terminal.
  - C. Install the "Alarm Must Sound" decal in the cab in FULL VIEW of the operator.  
**IMPORTANT:** THE BACK-UP ALARM SHOULD SOUND WHEN THE BACK-UP LIGHTS ARE ON.

10. Stabilizer Installation: See parts illustration on P6. Install stabilizer cylinders from bottom of stabilizer bumper into each outside pocket as shown. Make sure rod end cylinder head has been rotated to align ports with pins. Ports must face to front of truck and align through holes in front side of bumper. Install pins, washers, and cotter pins as shown. Install stabilizer slide weldment into bumper, blocking up so they stay in place. Next assemble shaft and roller, and pin cylinder to shaft to retain assembly together. Be sure both cylinders are completely retracted before completing the hydraulic installation. NOTE: Hydraulic cylinders are rephasing slave cylinders and must start out together or assembly will bind up and be damaged.

11. Loosen and remove nuts on studs at inlet plate. Add the stabilizer section 1 with o-rings 2 between inlet plate and 3<sup>rd</sup> section as shown. Using the longer stud bolts 3 supplied, **★reassemble valve and torque nut to 15 Ft. Lbs.**

12. Install (6) 3/4(M) O-Ring to 3/4(M) JIC Hydraulic fitting 8 into stabilizer cylinder and lock valve 7 as shown. Install (4) 3/4(F) JIC to 3/4(M) JIC 90° Fittings onto fitting 8. Install (2) 3/4(M) O-Ring to 3/4(M) JIC 90° fitting into valve 7. Install (2) 7/8(M) O-Ring to 3/4(M) JIC into 3rd section on control valve. Connect from control valve extend port to V2 port and retract port to V1 on lock valve 7 with hose 5. Connect from lock valve 7, port C2 to stabilizer cylinder base port on 21-1023 with hose 9. Connect cylinder rod end port to cylinder base port with hose 9. Connect from cylinder 21-1022 rod port to C1 on lock valve 7. Route hoses inside truck frame tied away from drive shaft, etc. Make sure cylinders are in phase before connecting all hoses. If cylinders are out of phase when first connecting hydraulics the stabilizer tubes and roller could be damaged. Hold valve open in retract direction to clear air and rephase cylinders.

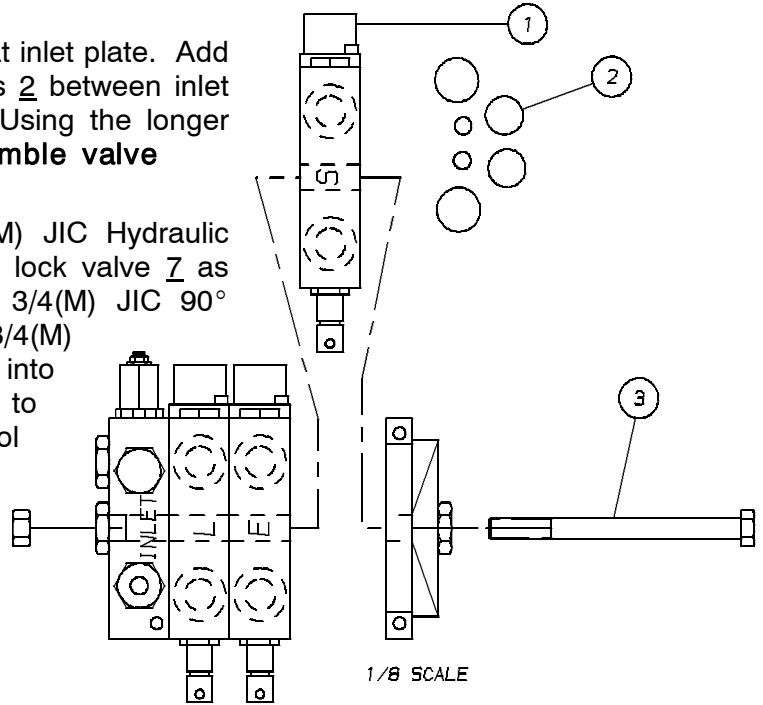

**IMPORTANT:** DEPENDING ON THE POSITION OF MOUNTING FEET AND PLATE USED, NEW HOLES MAY NEED TO BE DRILLED FOR THE NEW STUD BOLTS WHEN THE STABILIZER VALVE SECTION IS ADDED.

**★ MAKE SURE ALL SURFACES AND SEALS ARE CLEAN BEFORE REASSEMBLING THE VALVE.**

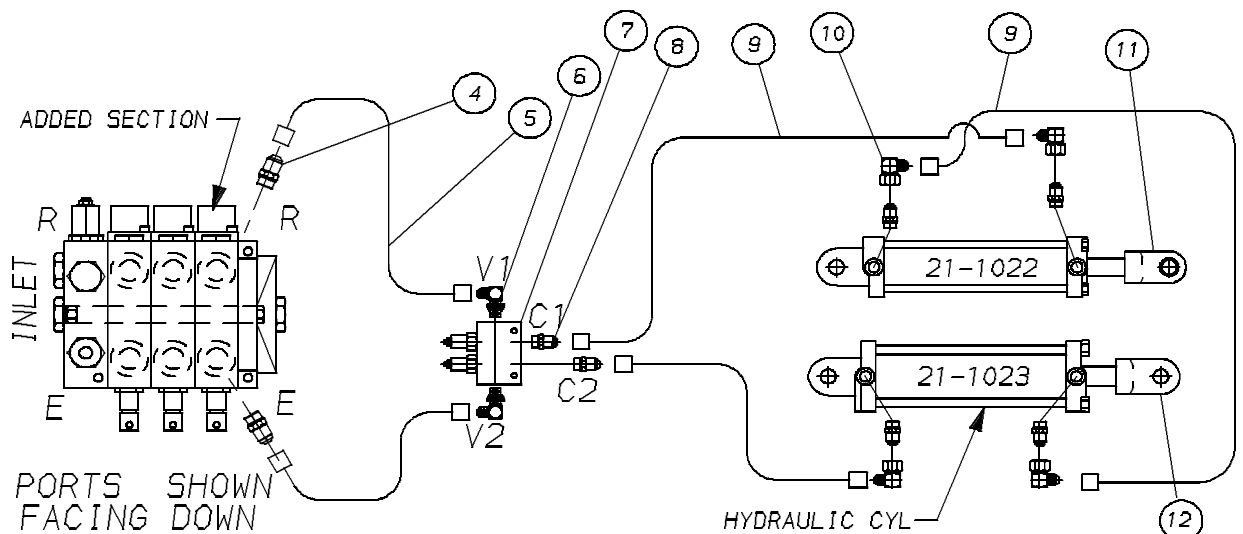

**NOTE:** CYLINDER END PLATE AT ROD MUST BE ROTATED 90 TO LINE UP WITH FITTING ON CYLINDER END PLATE IN LINE WITH PIN MOUNTING HOLE.

## HYDRAULIC SYSTEM START-UP PROCEDURE



**Caution:** Do not operate the pump until the system is filled with oil. Damage to the pump bearing and shafts can occur.

1. Fill the reservoir up to 2" from the top of the tank with a high quality of SAE 10 hydraulic oil i.e.: Shell (Tellus 22), Texaco (Rando 22) or Mobil DTE 25.

**IMPORTANT:** NEVER USE A FOAMING (DETERGENT) TYPE OIL.

2. Check the hoist for loose parts, tools, clamps or chains.
3. Check the overhead area for obstructions.
4. Clear all equipment from under the rear of the hoist.
5. Slowly extend the cylinders. Check for binding, rubbing of hoses or metal-to-metal interference between hoist and truck parts.
6. Operate all hydraulic functions to the full capacity for approximately 5 minutes in order to bleed off any entrapped air from the hydraulic system.



**Warning:** Escaping fluid under pressure can penetrate the skin causing serious injury. Avoid the hazard by relieving pressure before disconnecting hydraulic lines. Tighten all connections before applying pressure.



Search for leaks with a piece of cardboard. Protect hands and body from high pressure fluids.

If an accident occurs, see a doctor immediately. Any fluid injected into the skin must be surgically removed within a few hours or gangrene may result.

7. Perform a loading procedure with a flat rack or container to put the hydraulic system under load and check all connections and components for leaks.
8. If no leaks are visible, remove and replace the rack or container on the KP716 4 to 5 times to ensure that all moving parts are functioning freely and properly.
9. Load the flat rack or container with a load comparable to the full capacity of the KP716 and perform the loading and unloading procedure to ensure that all hydraulic lines and moving parts are functioning properly under load.
10. Operate the winch control and Free-Wheel Control to ensure that they are correctly adjusted and functioning properly.

# REFLECTIVE TAPE INSTALLATION

REF. ANSI STANDARD  
Z245.1-1999  
Z.2.16 VEHICLE CONSPICUITY

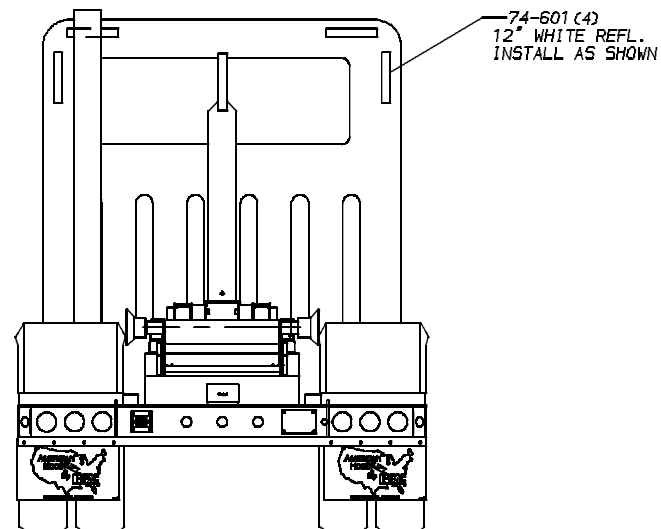
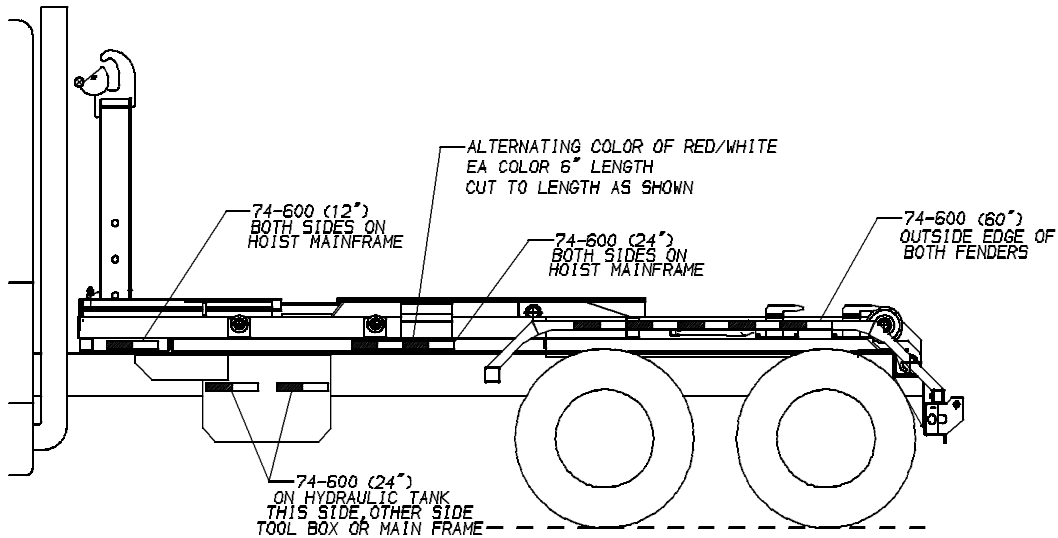
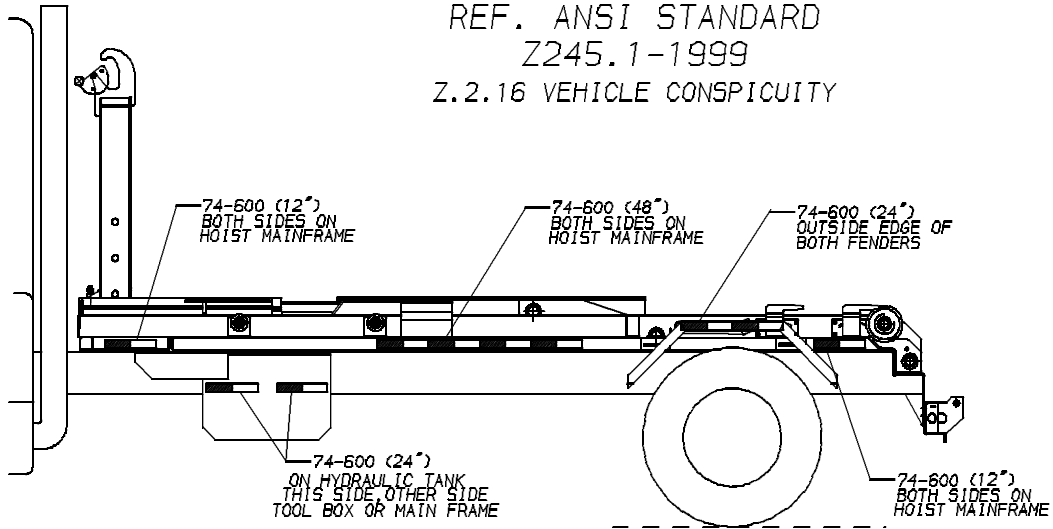

REFLECTIVE TAPE LOCATIONS AND LENGTHS ARE FOR REFERENCE,  
YOUR REFLECTIVE TAPE LOCATION MAY DIFFER DUE TO EQUIPMENT OPTIONS.  
REFLECTIVE TAPE TO COVER TRUCK CHASSIS OR HOIST FRAME,  
PER ANSI STANDARD Z245-1-1999

M9716-40  
REV. 2/28/02

**This page intentionally left blank.**